

## TEKNİK VERİLER | TECHNICAL DATA

### KAPALI DEVRE YÖN KONTROL VALFİ | CLOSED-LOOP DIRECTIONAL CONTROL VALVE

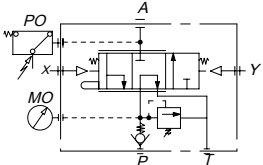
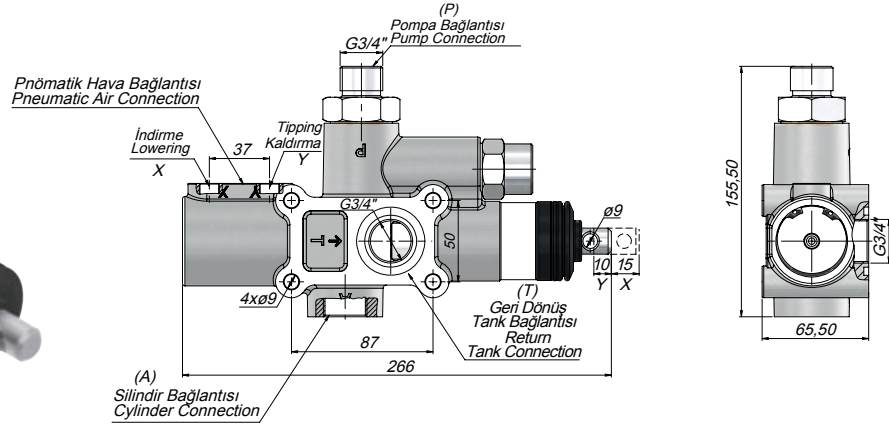

**HİDROLİK SEMBOL**  
HYDRAULIC SYMBOL

Kod Code	Debi Oranı Flow Rate	Max.Çalışma Basıncı Max.Working Pressure	Sıvı Sıcaklığı Fluid Temperature	Çalışma Viskosite Seviyesi Operating Viscosity Range	Havali Çalışma Basıncı Pneumatic Working Pressure
	(l/dk)	(Bar)	(°C)	(cSt)	(Bar)
VZM140	140	350	-10 ~+80~	-12-100 cSt	7-12