

TEKNİK VERİLER | TECHNICAL DATA

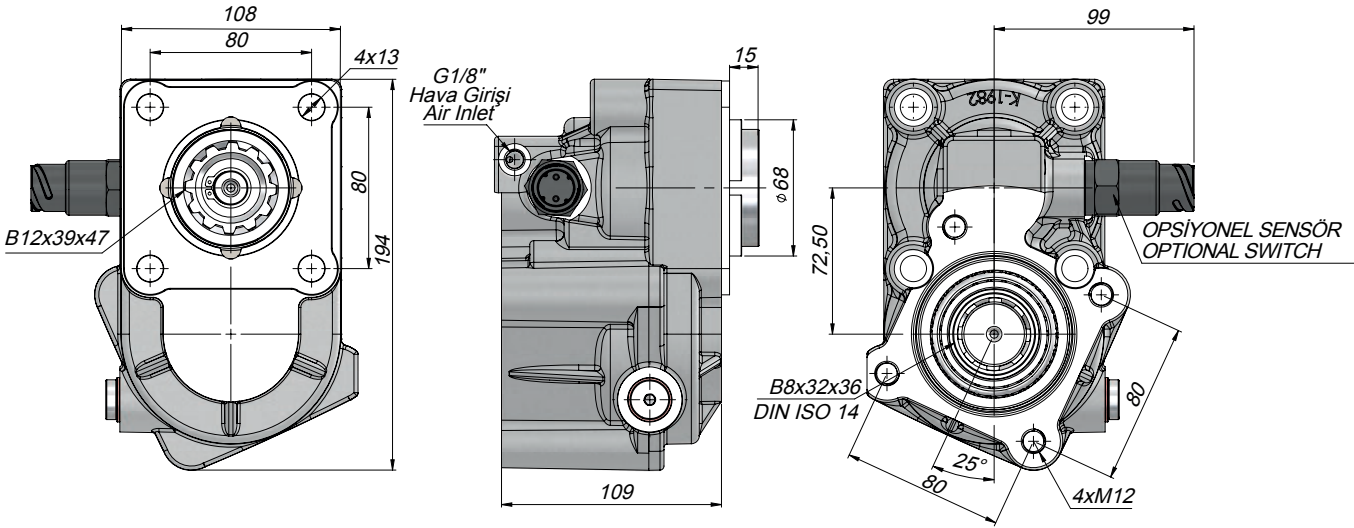

POWER TAKE
OFFS

| Kod Code | Şanzuman Modeli Gear Box Model | Havalı Çalışma Basıncı Pneumatical Working Pressure | Kontrol Sistemi Control System | Çevrim Oranı Ratio | Çıkış Tork Outlet Torque | | Güç Power | | Çıkış Hızı Output Speed | Dönüş Yönü Direction Of Rotation |
|-----------|--------------------------------------|--|-----------------------------------|-----------------------|-----------------------------|------|-------------------|-----------|----------------------------|-------------------------------------|
| | | (Bar) | | | (Kçm) | (Nm) | (Kw) 1000 dev/dak | (dev/dak) | | |
| PT2VCS18 | MERCEDES, IVECO, EATON, ZF, VOLVO | 7-12 | Havalı Pneumatic | 1,8 | 40 | 350 | 28.2 Hp | 20.7 Kw | 700 | Sol Left |
| PT2VCS153 | | | | | | 400 | | | | |
| PT2RCS133 | | | | | | 450 | | | | |

*(SW) - Switch
(WS) - Without Switch