

**TEKNİK VERİLER | TECHNICAL DATA**

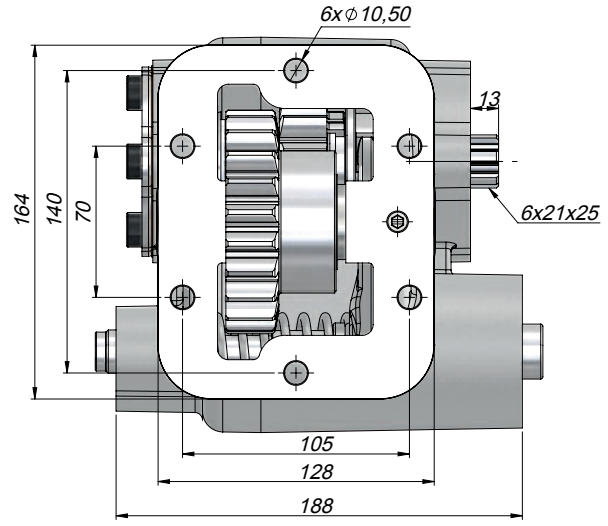

Kod Code	Araç Markası Vehicle Brand Track	Dişli Tipi Gear Type	P.T.O Tipi P.T.O Type	Kontrol Sistemi Control System	P.T.O Mil Dönüş Yönü P.T.O Shaft Rotation	Çıkış Tork Output Torque	Pto Mil Çıkış Devri Output Speed	Güç Power (Hp)
GBKM22UF42	Kamaz	Düz-Flat	Çift Dişli Double Teeth	Havalı Pneumatic	Sağ Right	25	600	213

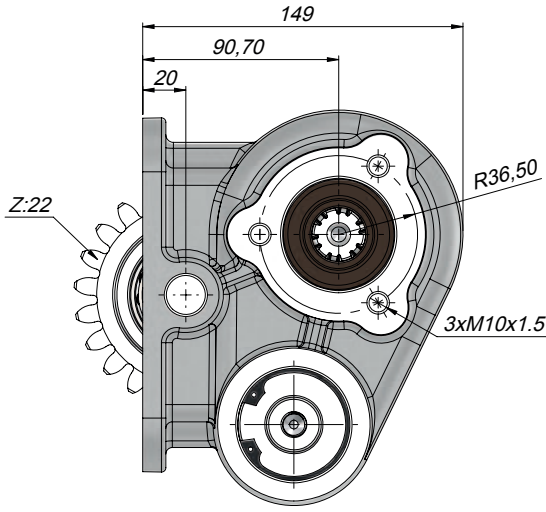
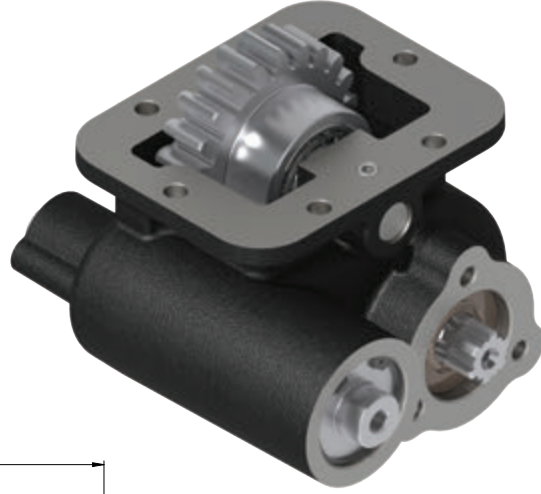
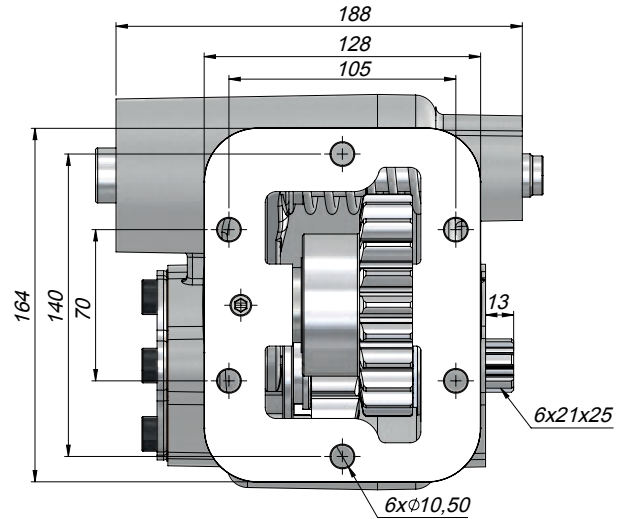
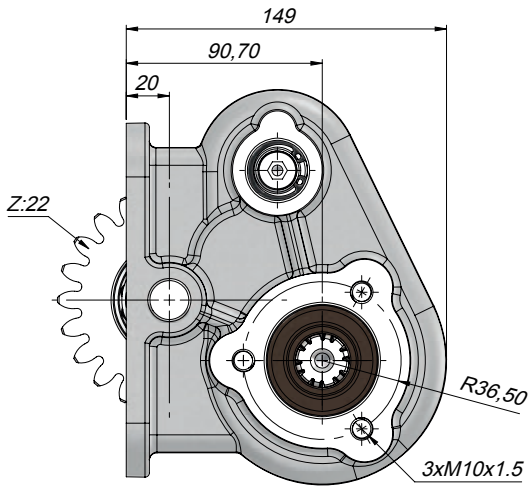

Kod Code	Araç Markası Vehicle Brand Track	Dişli Tipi Gear Type	P.T.O Tipi P.T.O Type	Kontrol Sistemi Control System	P.T.O Mil Dönüş Yönü P.T.O Shaft Rotation	Çıkış Tork Output Torque	Pto Mil Çıkış Devri Output Speed	Güç Power (Hp)
GBKM22UF41	Kamaz	Düz-Flat	Çift Dişli Double Teeth	Havalı Pneumatic	Sol Left	25	600	213